

Equipotential bonding of conducting parts of the electrical installation

High power gas discharge tube / LPZ 0_b-1 / IP67 / C €

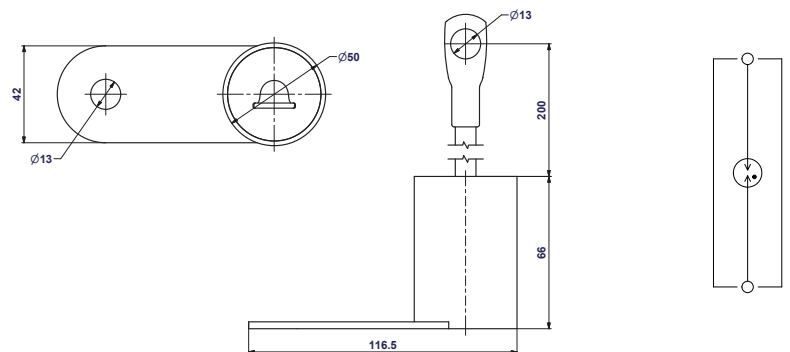

HGS 100 Ex

HGS 100 Ex – Separating high power gas discharge tube HGS 100 Ex for use in explosion hazards areas. It is intended for equipotential bonding of the installation parts of buildings or technological entities which are not interconnected operationally. In case of p.d. (potential difference) origin between those parts, the high power gas discharge tube ignites and interconnects both parts for a transient time (typical value of internal resistance at startup of HGS 100 Ex is $0,001 \div 0,002 \Omega$). Recommended installation is inside of the buildings, outdoors, in the

damp rooms as well as in the subterraneous areas.

It is an explosion-proof gas discharge tube with flexible connecting cable for equipotential bonding acc. to IEC 62305-1:2010 and also for the use in IT installations acc. to IEC 60364-5-54:2011. It complies with IEC 60079-0:2011, IEC 60079-18:2014 and IEC 60079-31:2013 standards. It is recommended for insulated flanges and insulated screw joints bridging in cathodic protected parts of industrial technology.

Type		HGS 100 Ex
EC-Type examination certificate		II 2G Ex mb IIC T6 Gb, II 2D Ex mb IIIC T80 °C Db
Approvals, certification		FTZU 04 ATEX 0255X
DC spark-over voltage		400 ÷ 750 V DC
Max. discharge current (8/20)	I_{max}	100 kA
Nominal discharge current (8/20)	I_n	75 kA
Max. lightning impulse current (10/350)	I_{imp}	100 kA
– charge	Q	50 As
– specific energy	W/R	2500 kJ / Ω
Voltage protection level at I_{imp}	U_p	< 1 kV
Insulation resistance at 100 V DC	R_i	< 1 G Ω
Capacitance at 1 MHz	C	25 pF
Housing material		corundum/binary resin with an external steel coat, resistant to climatic effects
Degree of protection of enclosure		IP67
Ambient temperature range for T Class T6	ϑ	-20 °C ÷ +30 °C
Lifetime		min. 100 000 h
Weight	m	550 g
Article number		10 201

Note: temperature class T6 is superior to all lower classes

Equipotential bonding of conducting parts of the electrical installation

II 2G Ex mb IIC T6 Gb

Equipment Group II

Electrical equipment of Group II is intended for use in locations with an explosive gaseous atmosphere other than underground mines with occurrence of methane (surface)

Equipment category 2G

Area use - zone 1, 2 according to EN 60079-10-1 (IEC 60079-10-1:2015)

Ex – Designation of equipment in potentially explosive areas

Type of protection m

potting with sealing compound
mb (for EPL protection level “Mb, Gb, Db”)

Gas Explosion Group IIC

Equipment labeled with IIC is suitable for use where Group IIA or Group IIB equipment is required

Temperature class T6 (maximum surface temperature)

T6 – 85 °C (carbon bisulphide, ethylnitrite and other gases with higher ignition temperature)

EPL protection level (what is the probability that a device will become a gas initiator)

Gb – equipment for explosive gaseous atmospheres that has a „high“ level of protection and it is not a source of ignition in normal operation or at expected failures

II 2D Ex mb IIIC T80 °C Db

Equipment Group II

equipment for potentially explosive atmospheres other than underground mines with occurrence of gas (methane) and / or combustible dust

Equipment category 2D

Area use – zone 21, 22 according to EN 60079-10-1 (IEC 60079-10-1:2015)

Ex – Designation of equipment in potentially explosive areas

Type of protection m

potting with sealing compound
mb (for EPL protection level “Mb, Gb, Db”)

Dust explosion group IIIC (categorized according to the characteristics of the dust explosive atmosphere)

IIIC conductive dusts

Maximum surface temperature T80 °C (the highest temperature that occurs when operating in the most adverse conditions (but within confirmed tolerances) on any part of the electrical equipment surface)

Protection level EPL Db

Db – equipment for dust explosive atmospheres, which has a „high“ level of protection and it is not a source of ignition in normal operation or at expected faults